

Mekpa 380 V Diphase Wa Battery Charger Main Circuit Diagram 2021-2022

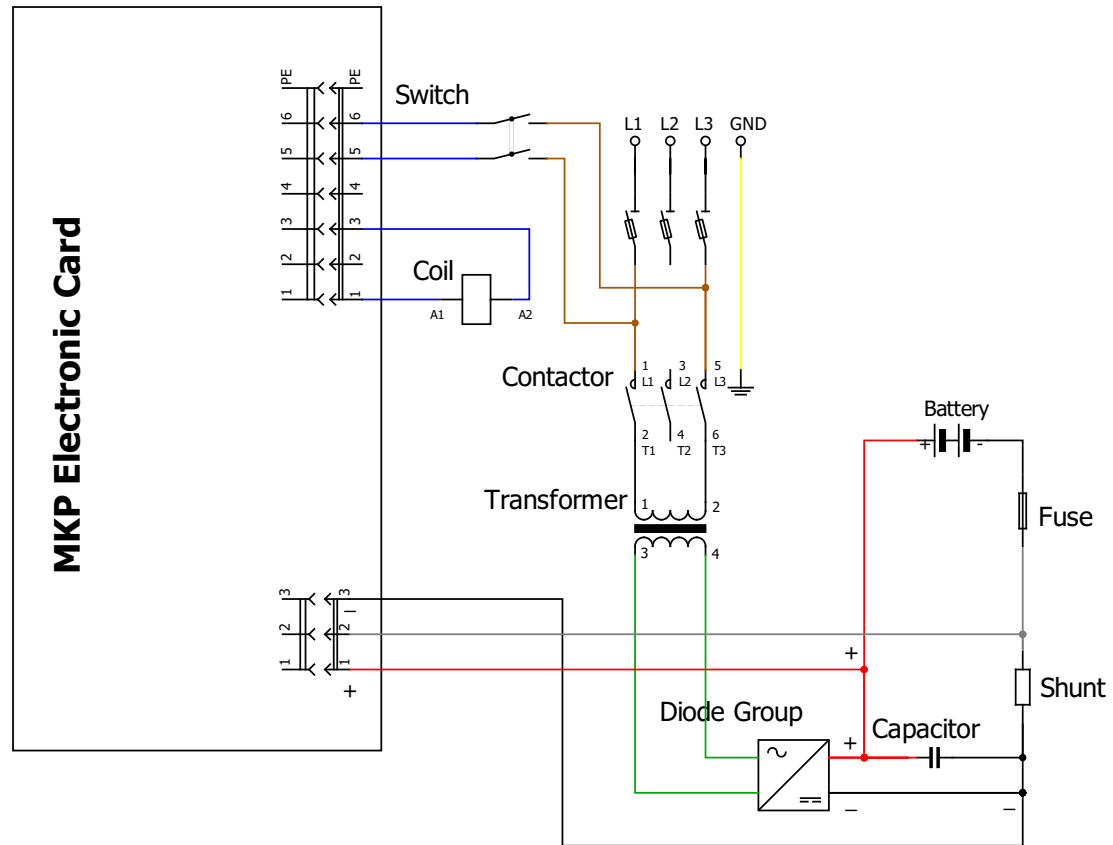

Transformer pin 1 -> 0V
Transformer pin 2 -> 400V

Mekpa 220 V Monophase Wa Battery Charger Main Circuit Diagram 2021-2022

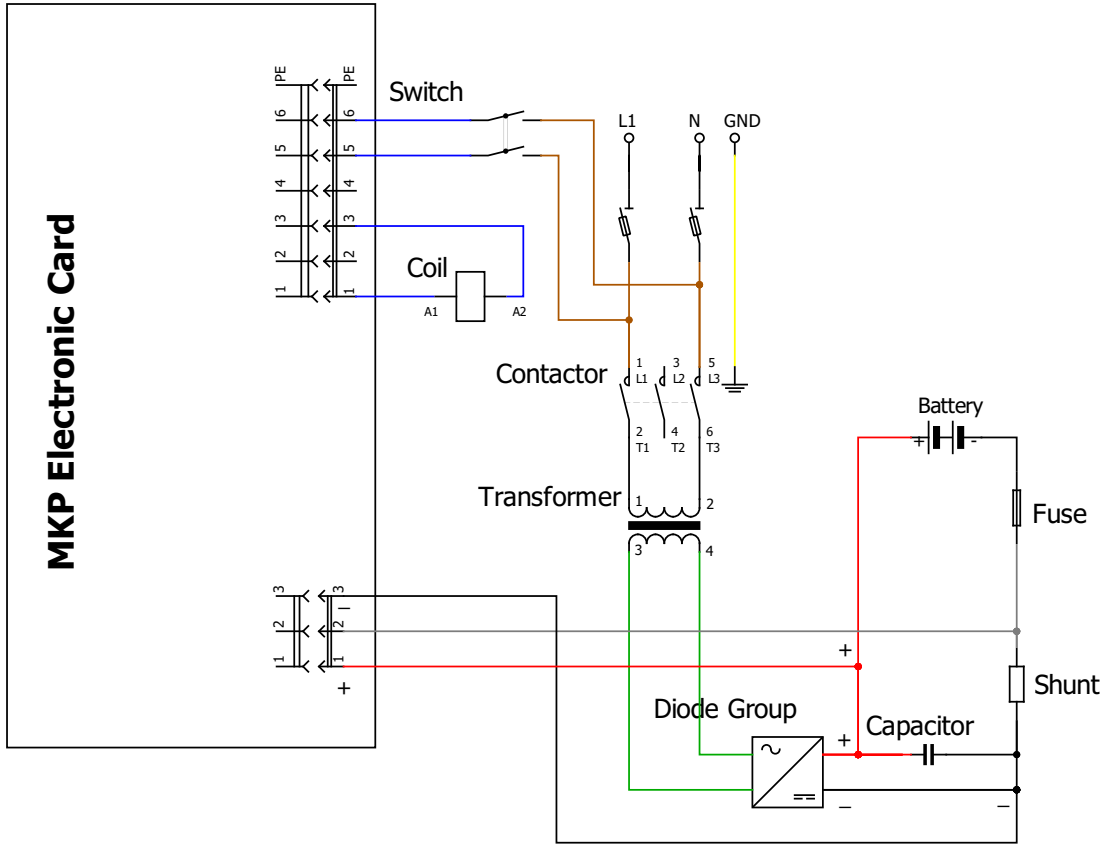

Transformer pin 1 -> 0V
Transformer pin 2 -> 230V

Mekpa 380 V Threephase Wa Battery Charger Main Circuit Diagram 2021-2022

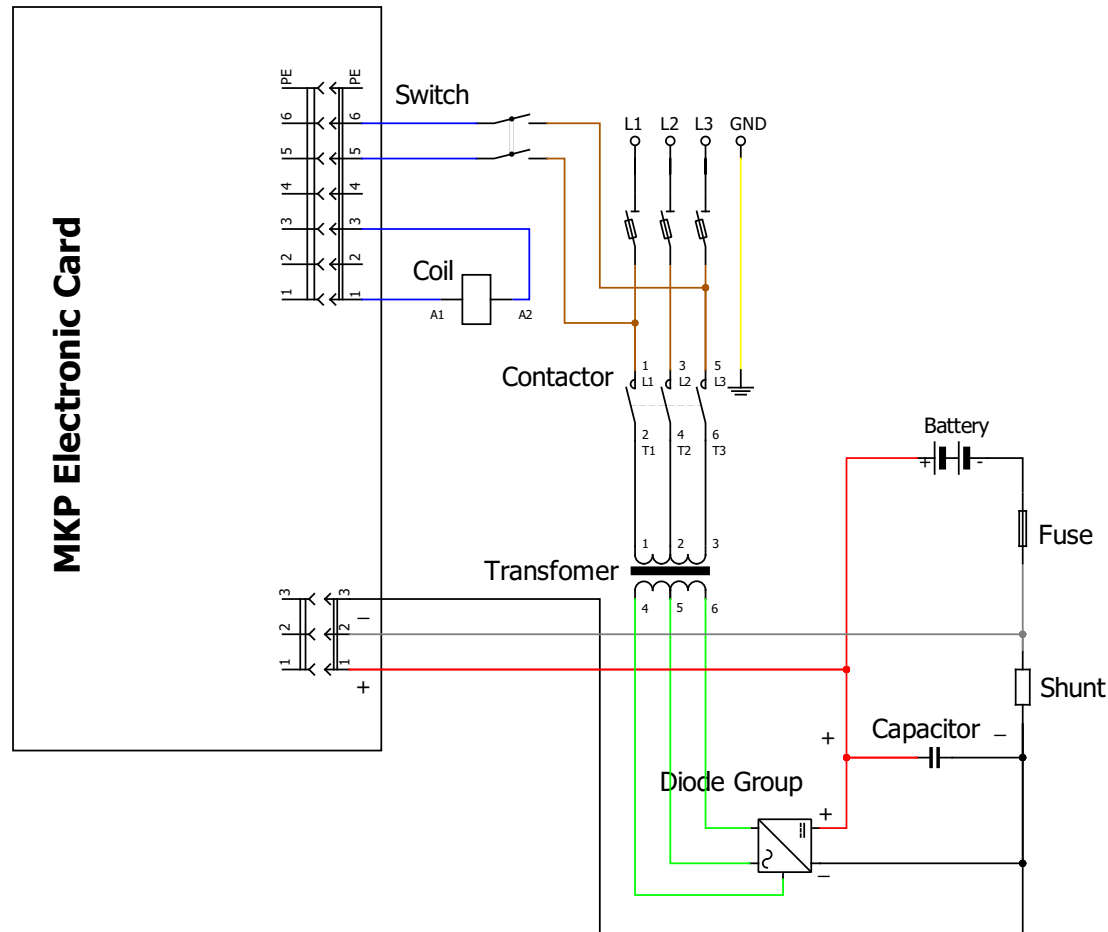

Transformer pin 1 -> 400V - L1
Transformer pin 2 -> 400V - L2
Transformer pin 3 -> 400V - L3

Mekpa 220 V Monophase Wo-Wa Battery Charger Main Circuit Diagram 2021-2022

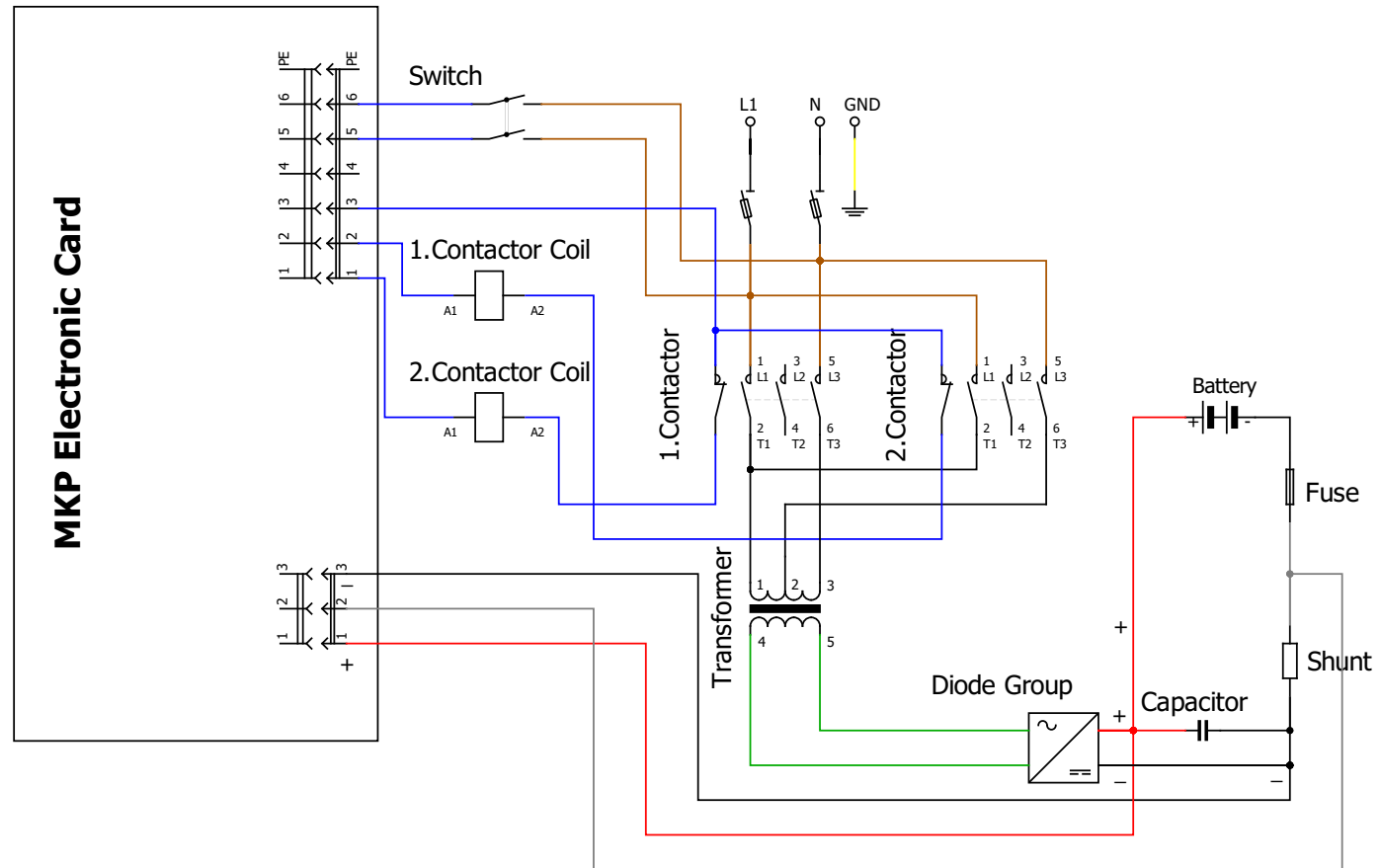

Transformer pin 1 -> 0V
Transformer pin 2 -> 220V
Transformer pin 3 -> 230V

Mekpa 380 V Diphase Wo-Wa Battery Charger Main Circuit Diagram 2021-2022

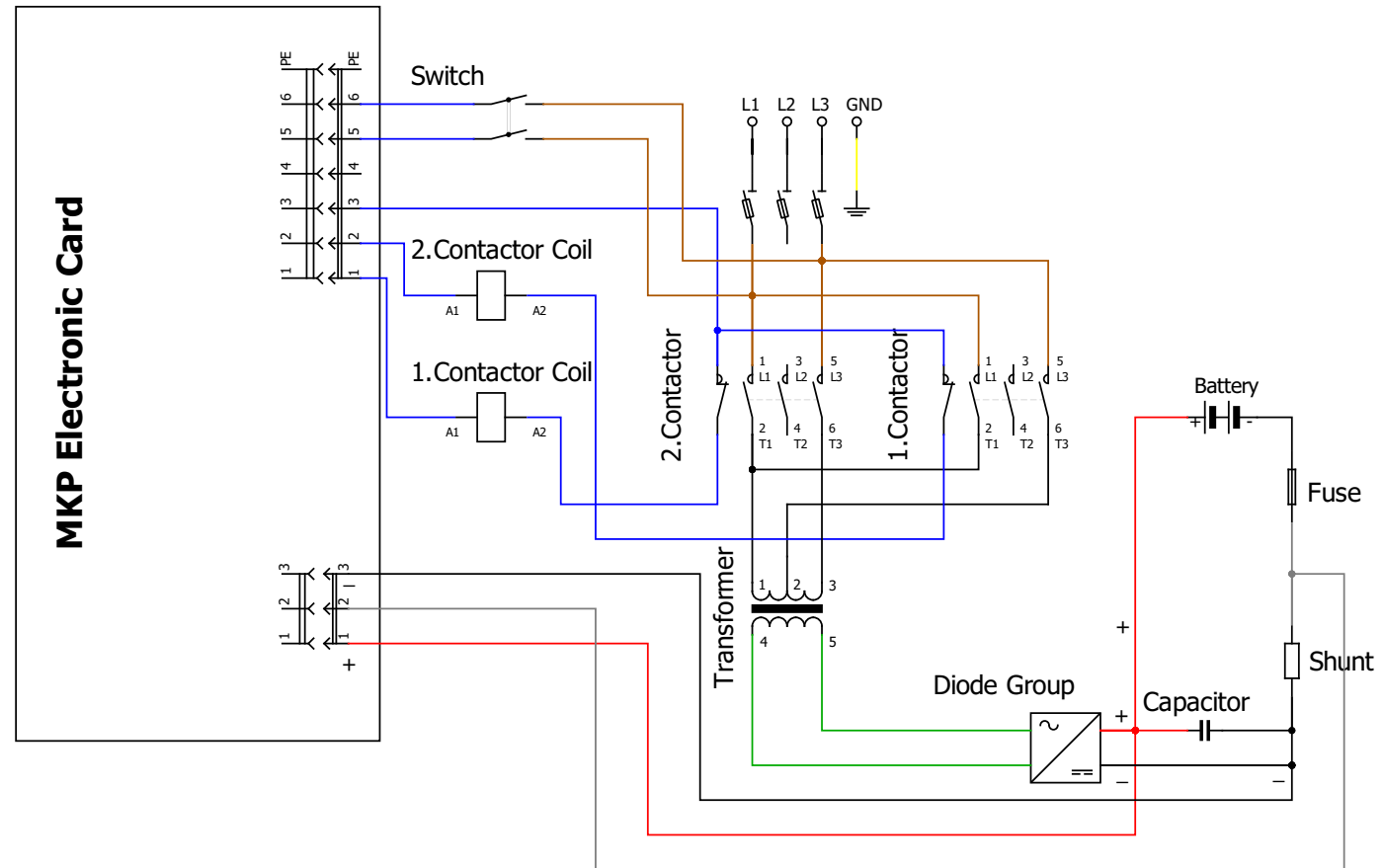

Transformer pin 1 -> 0V
Transformer pin 2 -> 380V
Transformer pin 3 -> 400V

Mekpa 380 V Threephase Wo-Wa Battery Charger Main Circuit Diagram 2021-2022

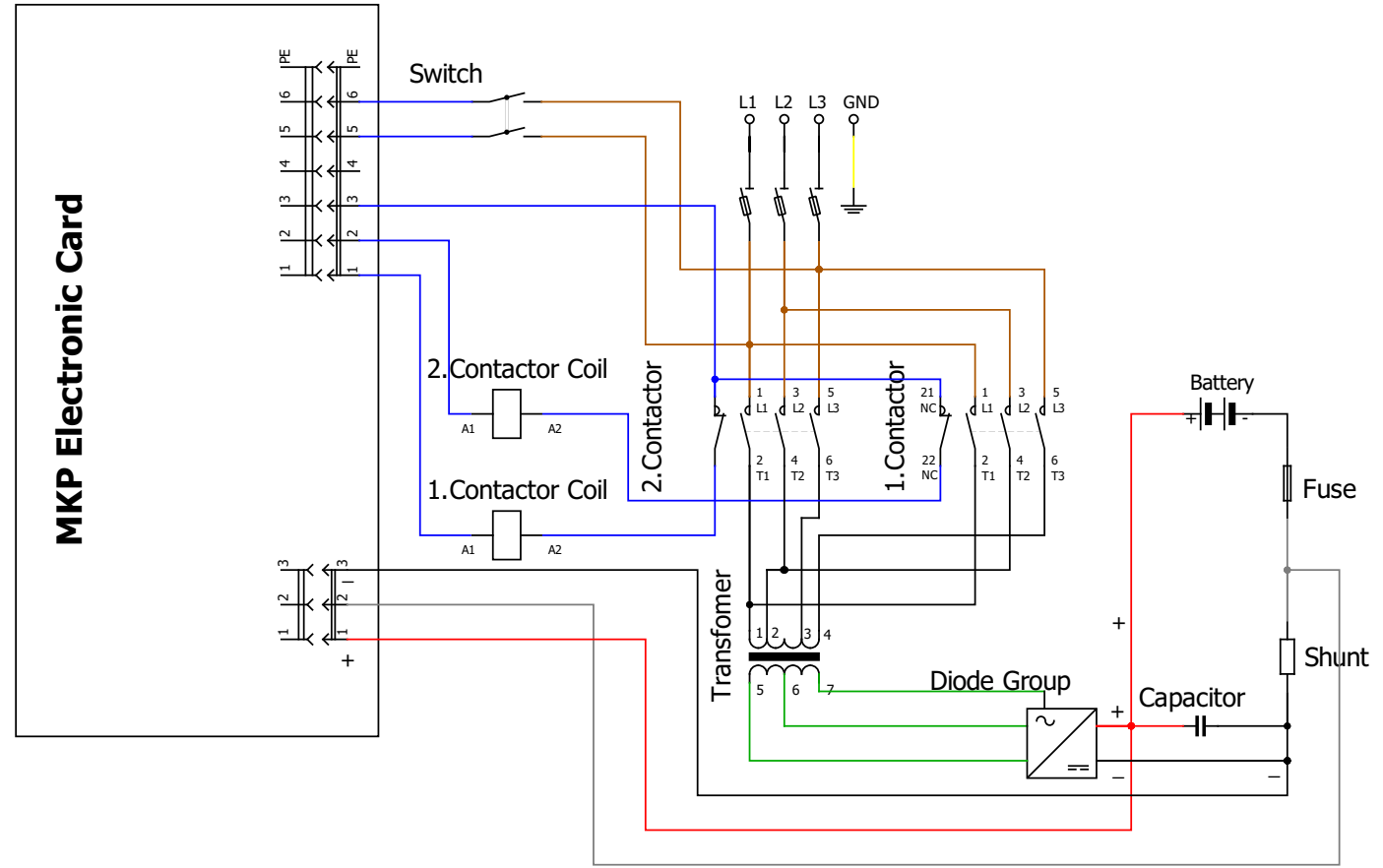

Transformer pin 1 -> 400V - L1
Transformer pin 2 -> 380V - L2
Transformer pin 3 -> 400V - L2
Transformer pin 4 -> 400V - L3